

BELT-PACK 4-WIRE BOX type C1B

The C1B is a compact battery-powered 4-wire box for headset use only. Selectable operating modes suit various applications in a number of studio and outside broadcast situations where 4-wire communications are used

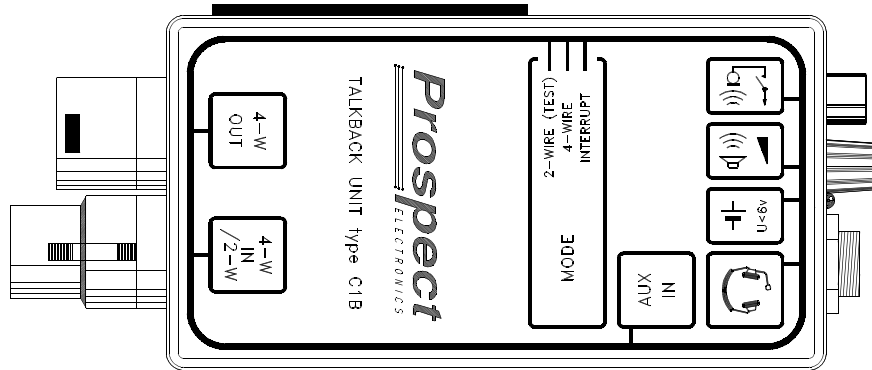

FEATURES

- * Three user-selectable operating modes:-
 - 4-wire mode.
 - Interrupted loop-through mode with input monitoring.
 - 2-wire Conference mode.
- * 9 volt battery powered with very low current drain (2mA).
- * Microphone limiter to maintain peak output at +8dBu.
- * Auxiliary audio monitoring input on unbalanced 3.5mm jack.

DESCRIPTION

Direct compatibility with other communications equipment is provided by the use of 4-wire operation as opposed to the more common, line-powered 2-wire belt-pack systems. Greater flexibility resulting from 4-wire operation also enables both interrupt and 2-wire modes to be easily selected by the user.

The IFB option is typically used to provide an interrupted programme feed to a presenter's earpiece when the talk switch is pressed, while simultaneously allowing the programme sound to be monitored on the headset. As the signal is switched directly between the input and output connectors, the programme signal path is fail-safe and does not require the unit to be powered.

In 2-wire mode, a number of C1B units can simply be connected in parallel, enabling all units to communicate with each other in conference mode. As the unit's microphone signal is also heard in the headphones, this mode also provides a quick method of testing the correct operation of the unit and headset. The 6-channel talkback unit type C6R has been designed to allow several C1B units in 2-wire mode to be connected to channel 6, typically to provide camera talkback on a single key.

To provide compatibility with earpieces which use a mono jack plug, the tip connection on the headset jack socket supplies the output for the headphone(s), the ring connection providing the microphone input. The auxiliary input jack can be used in all modes to monitor any additional line-level signal such as a tape machine playback, etc..

BELT-PACK 4-WIRE BOX type C1B

BLOCK DIAGRAM

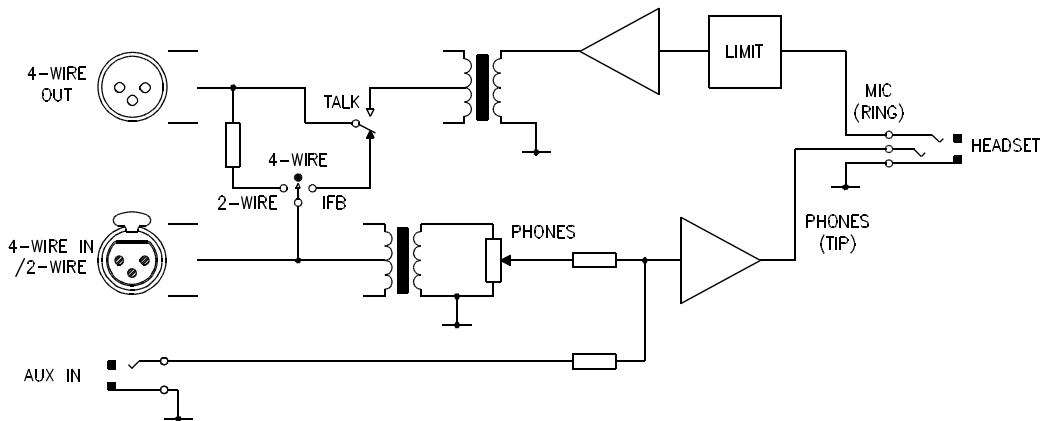

SPECIFICATIONS

MICROPHONE INPUT / LINE OUTPUT AMPLIFIER

INPUT IMPEDANCE	Unbalanced for 200 ohm dynamic microphone
MICROPHONE CONNECTOR	6.35mm (A-gauge) headset jack. Ring input, sleeve gnd
LIMITER INPUT THRESHOLD	-62dBu
LINE OUTPUT LEVEL	+8dBu peak (battery voltage > 6V)
OUTPUT IMPEDANCE	150 ohms, transformer coupled
LINE CONNECTOR	XLR3M

LINE INPUT / HEADPHONE AMPLIFIER

LINE INPUT IMPEDANCE	10k ohms, transformer coupled
LINE INPUT CONNECTOR	XLR3F
GAIN RANGE	+10dB to off
AUXILIARY INPUT IMPEDANCE	Unbalanced high impedance
AUXILIARY INPUT CONNECTOR	3.5mm jack
GAIN	Fixed 0dB
MAX LINE/AUX INPUT LEVEL	+8dBu
MAXIMUM OUTPUT LEVEL	30mW in 100 ohm load (minimum load impedance)
HEADPHONE CONNECTOR	6.35mm (A-gauge) headset jack. Tip output, sleeve gnd

2-WIRE MODE

Line impedance: 10k ohms (listen), 600 ohms (talk)

POWER SUPPLY

PP3 9V battery (in drawer), current 2mA
LED low voltage warning at 6V

PHYSICAL

DIMENSIONS	150 x 65 x 40mm
WEIGHT	375g
CASE	Diecast metal with light grey & black finish